

TYPICAL GARDEN BLOCK WALL SECTION - LEVEL BACKFILL NO SURCHARGE

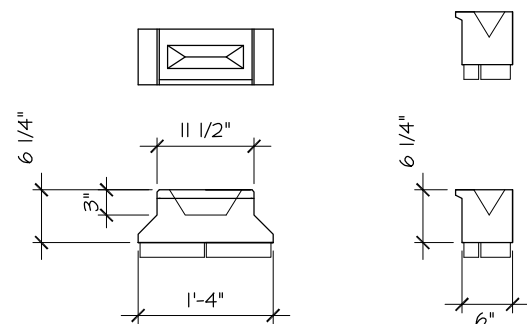

SOIL PROPERTIES:

LOCATION:	FRICTION ANGLE DEG.	UNIT WT. PCF	COHESION LBS/SF
REINFORCED FILL MATERIAL	50	120	0
RETAINED BACK FILL	28	120	0
FOUNDATION SOIL	28	120	0
BEARING	2000 PSF		

REINFORCED FILL MATERIAL SPECIFICATION

THE REINFORCED BACKFILL SHALL MEET THE FOLLOWING GRADATION OR A GRADATION APPROVED BY THE ENGINEER AND SHALL BE FREE OF DELETERIOUS MATERIALS.

SIEVE SIZE	PERCENT PASSING
1 1/2"	100
3/4"	65-95
3/8"	36-70
#10	10-30
#200	0-10

SUBGRADE SOIL SPECIFICATION

IF THE SUBGRADE SOIL BENEATH THE REINFORCED BACKFILL CONSISTS OF FILL, THE SUBGRADE SOIL SHALL HAVE A MINIMUM MOISTURE CONTENT OF 2% BELOW THE SOIL'S OPTIMUM MOISTURE CONTENT AND SHALL BE COMPACTED TO A MINIMUM OF 95% OF THE SOIL'S MAXIMUM DRY. THE SOIL'S OPTIMUM MOISTURE CONTENT AND MAXIMUM DENSITY SHALL BE DETERMINED IN ACCORDANCE WITH ASTM D 698.

IF THE SUBGRADE SOIL BENEATH THE REINFORCED BACKFILL CONSISTS OF NATURAL SOIL, THE SUBGRADE SOIL SHALL BE PROOFROLLED WITH A LOADED DUMP TRUCK OR SIMILAR PIECE OF EQUIPMENT TO LOCATE UNSTABLE MATERIALS. ANY UNSTABLE MATERIAL SHOULD BE EITHER REMOVED AND REPLACED WITH PROPERLY PLACED FILL OR REWORKED TO CONFORM TO THE MOISTURE CONTENT AND COMPACTION SPECIFICATIONS PRESENTED ABOVE.

GENERAL NOTES FOR USING THIS TABLE

1. THE REINFORCE GRANULAR MATERIAL MUST BE FREE DRAINING WITH ADEQUATE SLOPE WITHOUT WATER RETENTION.
2. THE SUBGRADE FOR THE RETAINING WALL MUST BE TESTED FOR LOADING FROM RETAINING WALL ABOVE.
3. THE MAXIMUM SURCHARGE IS 100 PSF UNIFORM LOADING. THIS IS NOT DESIGNED FOR VEHICULAR TRAFFIC OR PARKING ABOVE SOIL RETAINAGE.
4. THE MIRAGRID 3XT SHALL BE STRETCH TIGHT DURING PLACEMENT OF THE GRANULAR BACKFILL.
5. THE MIRAGRID 3XT SHALL BE SET FLUSH WITH THE EXTERIOR FACE OF THE SEGMENTAL RETAINING WALL BLOCK.
6. THE DESIGN TABLES ARE FOR THE CONSTRUCTION OF GRANULAR REINFORCED BACKFILL SOIL IS NOT ALLOWED IN THE REINFORCED AREA. THE GRANULAR FILL FRICTION ANGLE IS TO BE A MINIMUM OF 50 DEGREES.
7. THE DESIGNS ARE BASED ON WELL DRAINED SOILS.
8. HIGH PLASTIC SOILS SHOULD BE AVOIDED WITH OUT SPECIAL DESIGN MODIFICATIONS BY AN ENGINEER. CONSULT WITH AN ENGINEER IF WALLS ARE TO BE IN CONTINUOUS CONTACT WITH WATER, I.E. RIVERS, LAKES, AND PONDS.
7. A ENGINEER MUST REVIEW THE SOIL AND BACKFILL MATERIAL PROPERTIES TO VERIFY THESE DESIGNS.
8. REVISED 6/22/10.

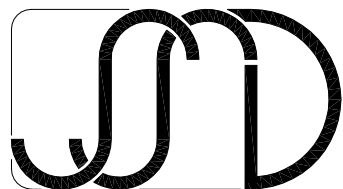

Structural Systems Design, Inc.
 1701 Cushman Dr. #5
 Lincoln, NE 68521
 PHONE:(402) 421-1133
 FAX:(402) 421-1244

NATURAL CONCRETE PRODUCTS
SEGMENTAL RETAINING WALL

PROJECT NO:
05.043
 DRAWN BY:
JH
 ©COPYRIGHT
SSD 2008

C1